

711 W. 40TH STREET | BALTIMORE, MD 21211

PROPERTY OVERVIEW

HIGHLIGHTS:

- Local ownership with deep ties to Baltimore City
- Abundant on-site amenities including Starbucks, MOM's, Bank of America, Medium Rare, and soon to arrive The Lodge Restaurant
- Multiple Office Spaces Available
- On-site property management with 24 hr. security guard staff
- Close proximity to downtown Baltimore, I-83, & I-695
- 900 on-site garage spaces & 300+ surface spaces

AVAILABLE FOR LEASE:

SUITE 200 - 4,441 SF
SUITE 200B - 4,523 SF
SUITE 210 - 318 SF
SUITE 212A - 1,739 SF
SUITE 212 - 3,293 SF
SUITE 218 - 2,273 SF
SUITE 235 - 9,000 SF
SUITE 300 - 1,506 SF
SUITE 318A - 310 SF
SUITE 319 - 459 SF
SUITE 320 - 300 SF
SUITE 321 - 931 SF
SUITE 322 - 462 SF
SUITE 360 - 1,099 SF
SUITE 425 - 823 SF
SUITE 428 - 1,117 SF
SUITE 438 - 1,883 SF

RENTAL RATE:

OFFICE: \$32.50/ SF, FS



GOOGLE STREET VIEW



SITE PLAN

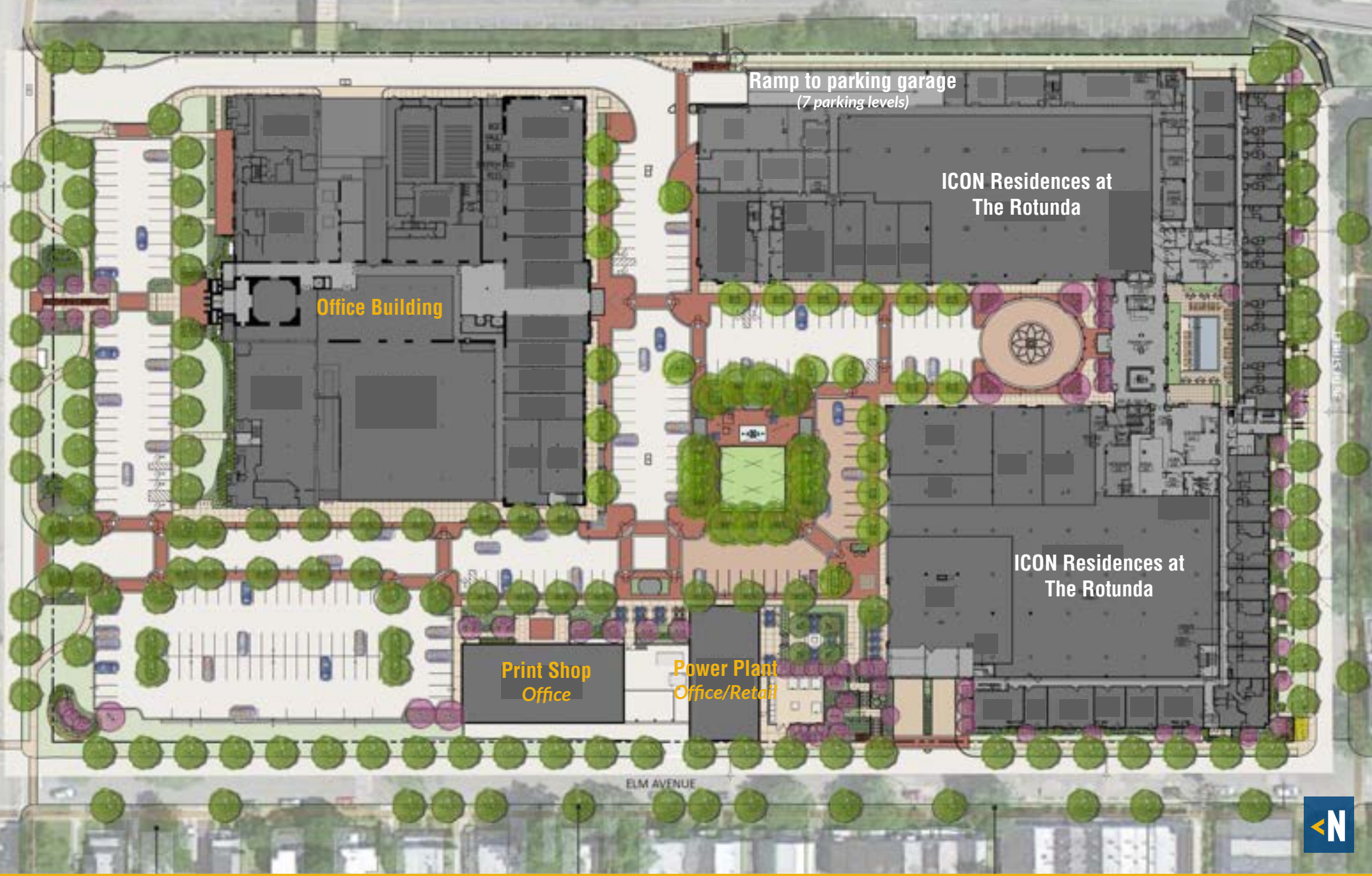

FLOOR PLAN



SUITE 200B: 4,523 SF

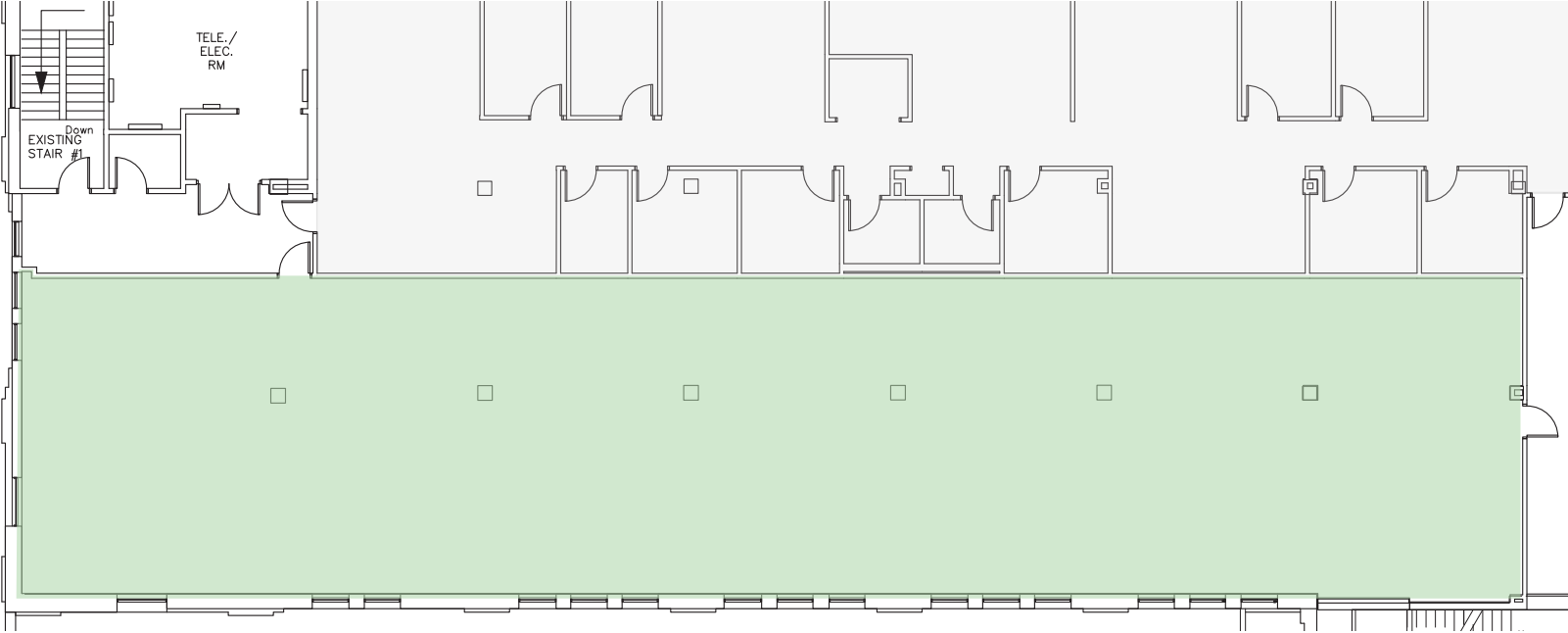

FLOOR PLAN



SUITE 210: 318 SF

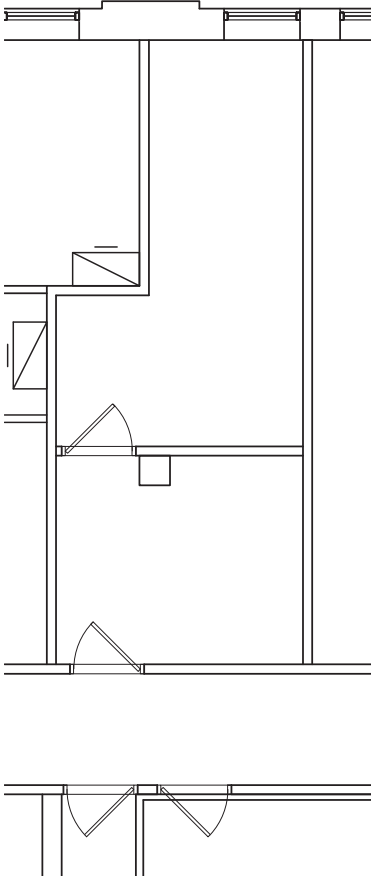

SUITE 212A: 1,739 SF

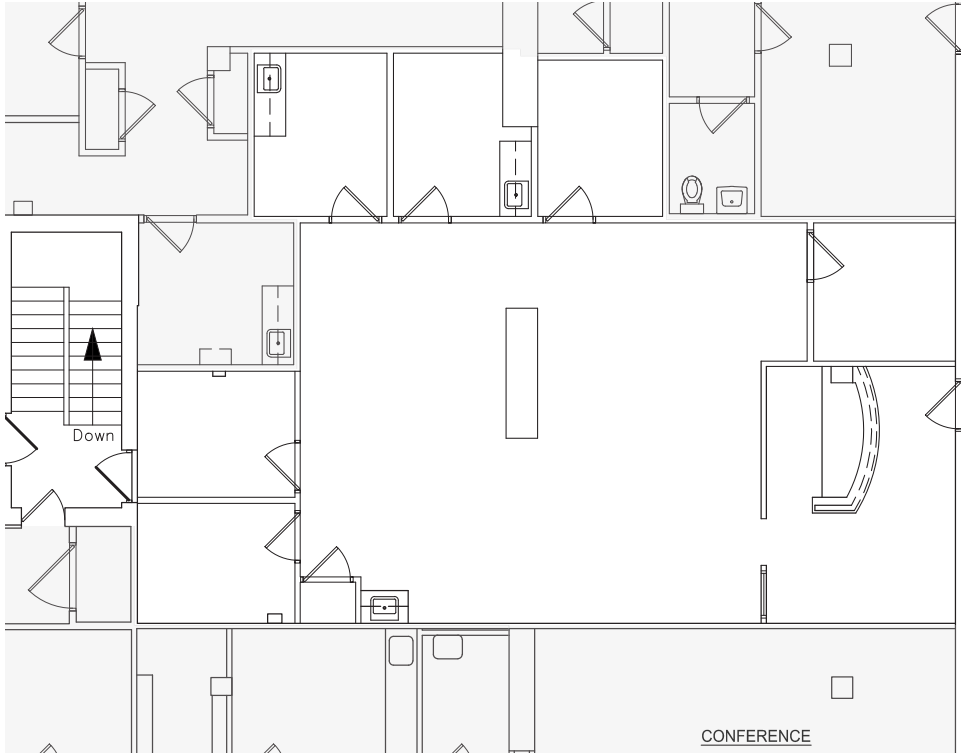

FLOOR PLAN



SUITE 212: 3,293 SF

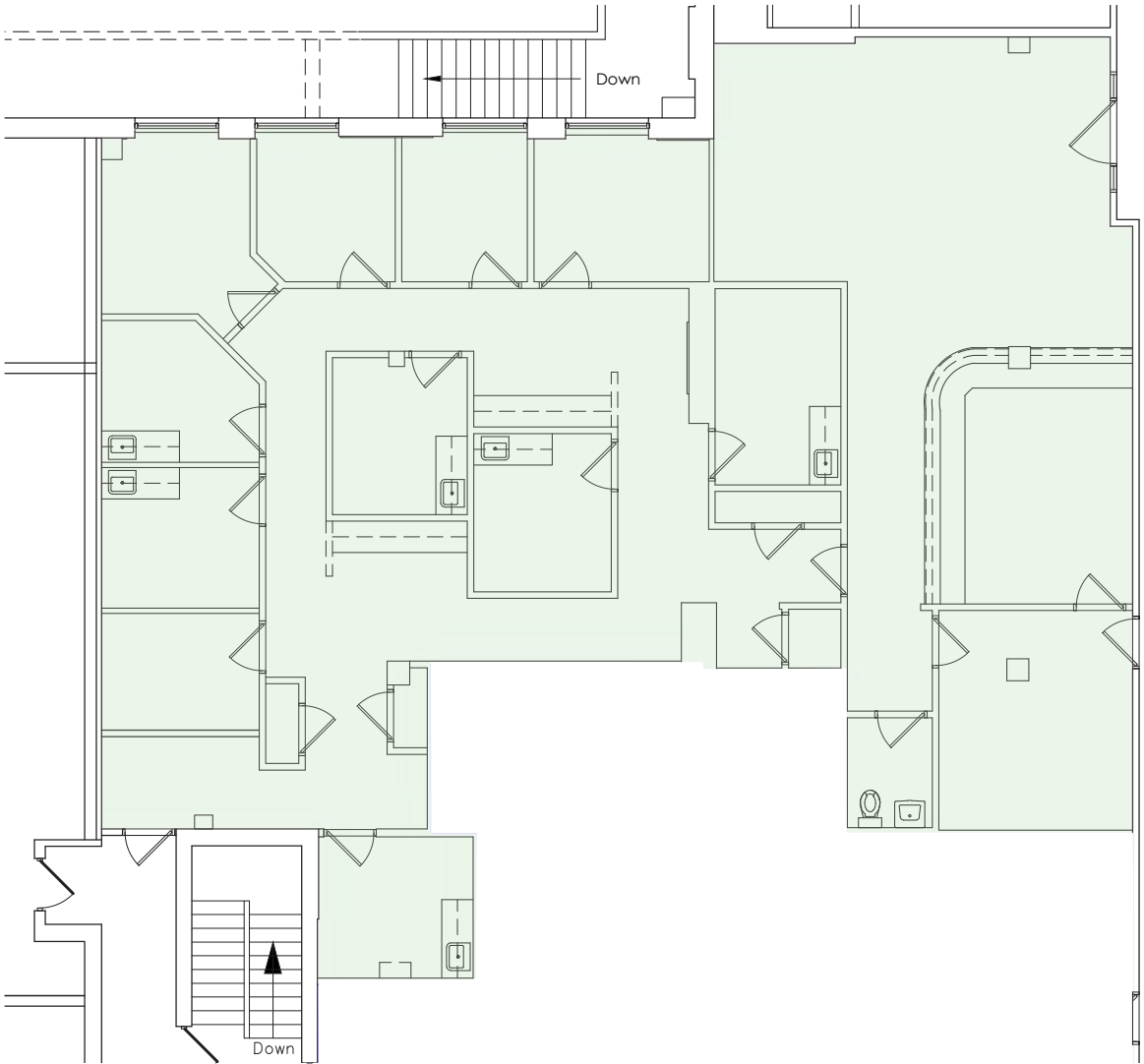

FLOOR PLAN



SUITE 218: 2,273 SF

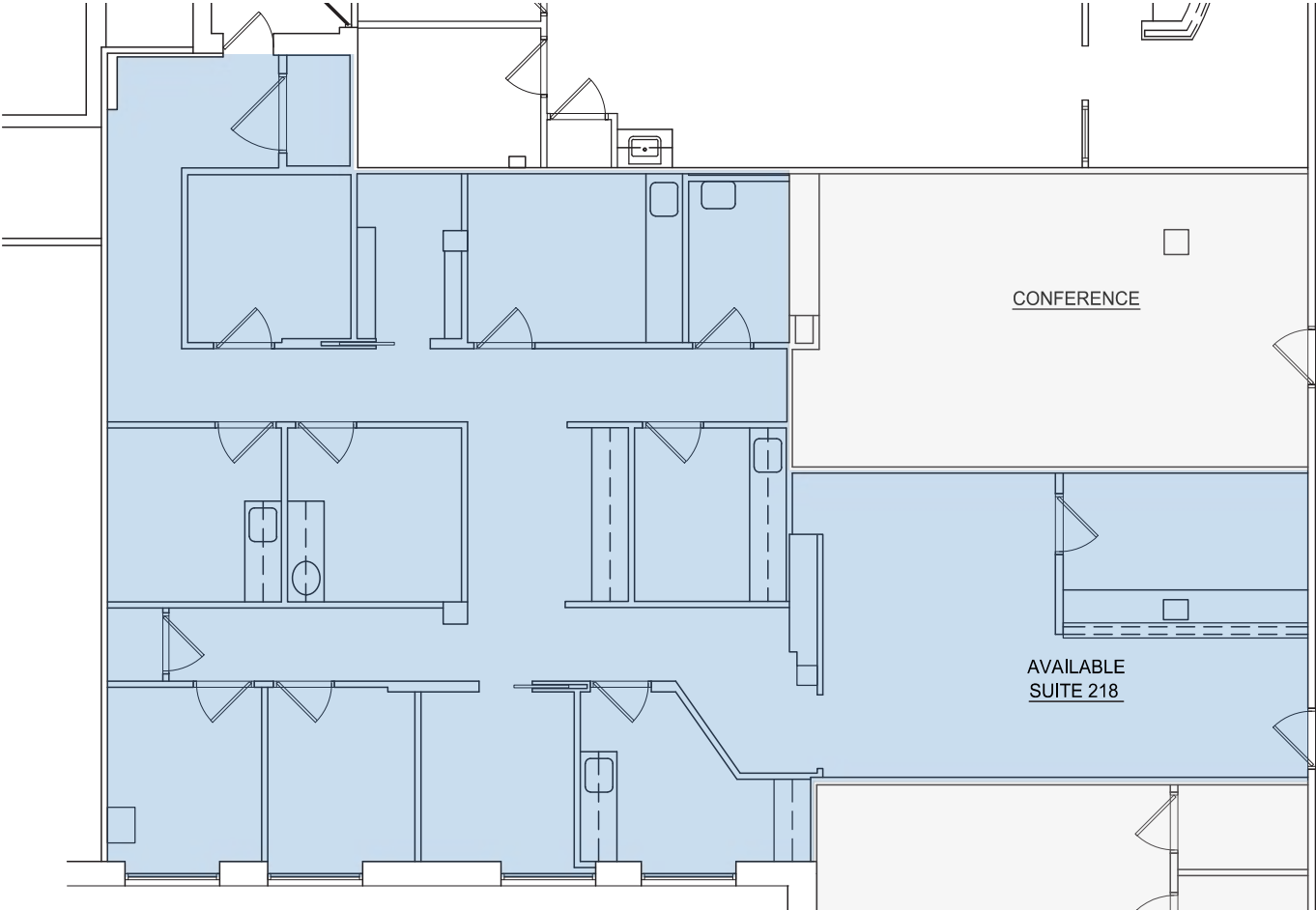

1 SUITES 218
ID-1 1/8"=1'-0"

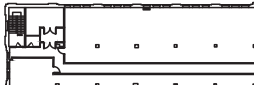

FLOOR PLAN



SUITE 235: 9,000 SF

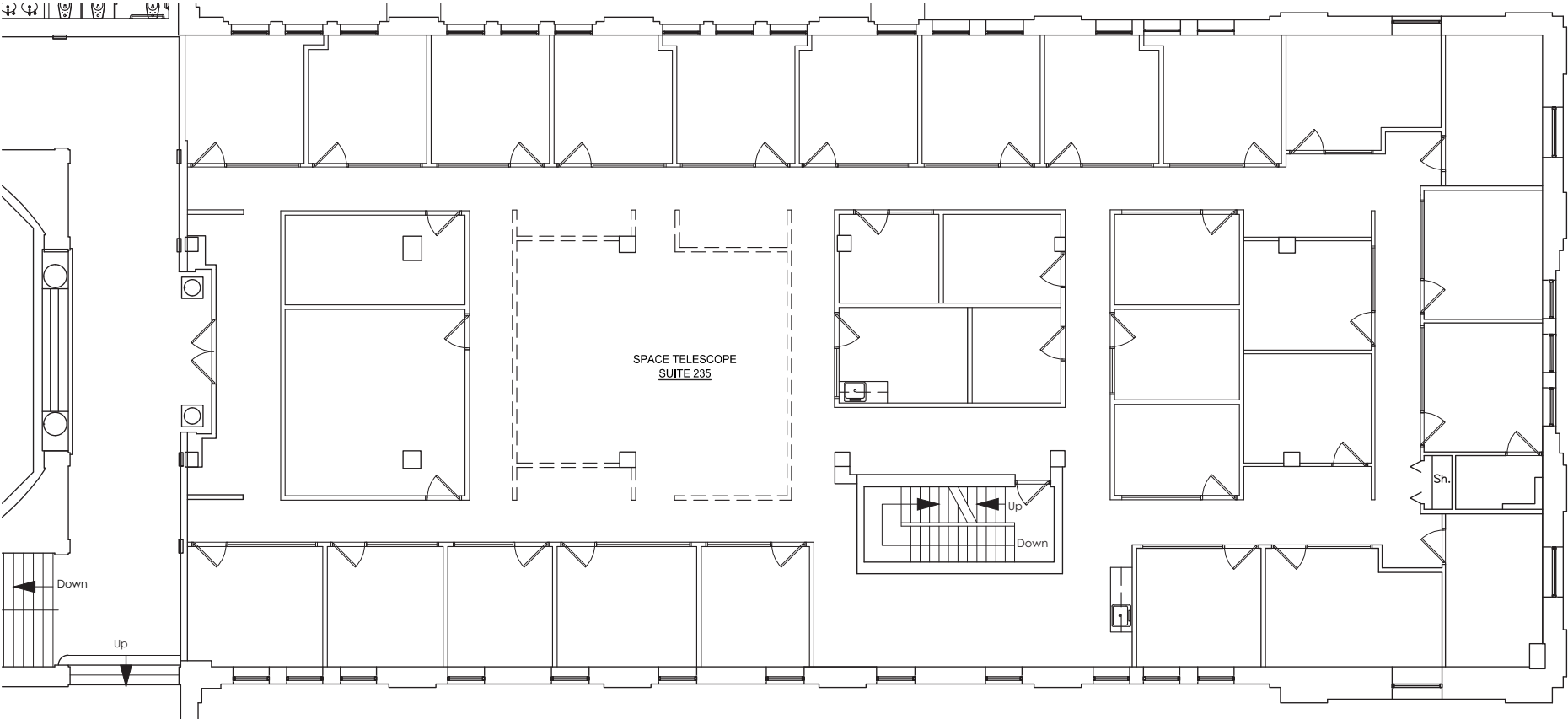

FLOOR PLAN



SUITE 300: 1,506 SF

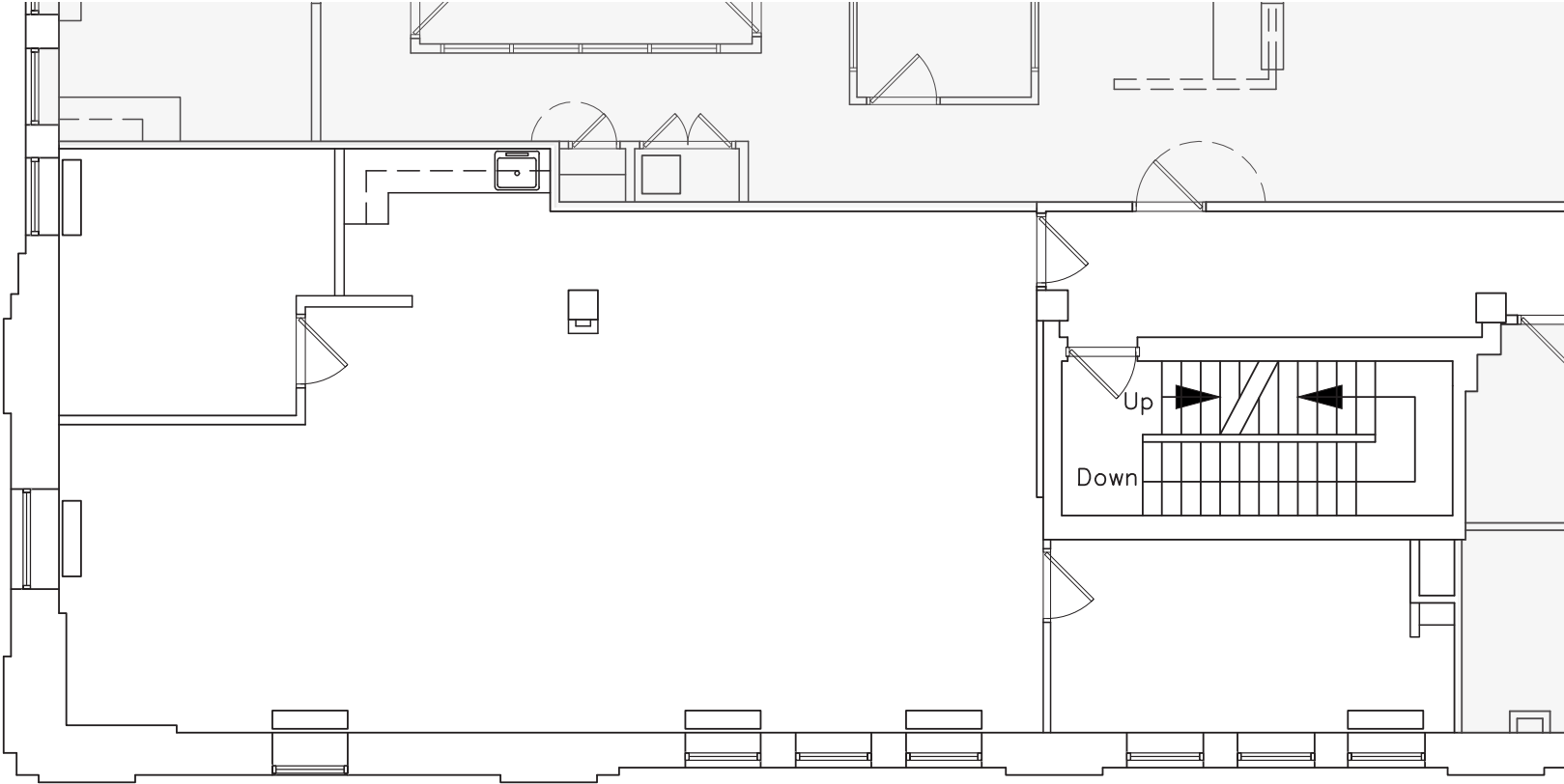

FLOOR PLAN



SUITE 319: 459 SF

SUITE 321: 930 SF

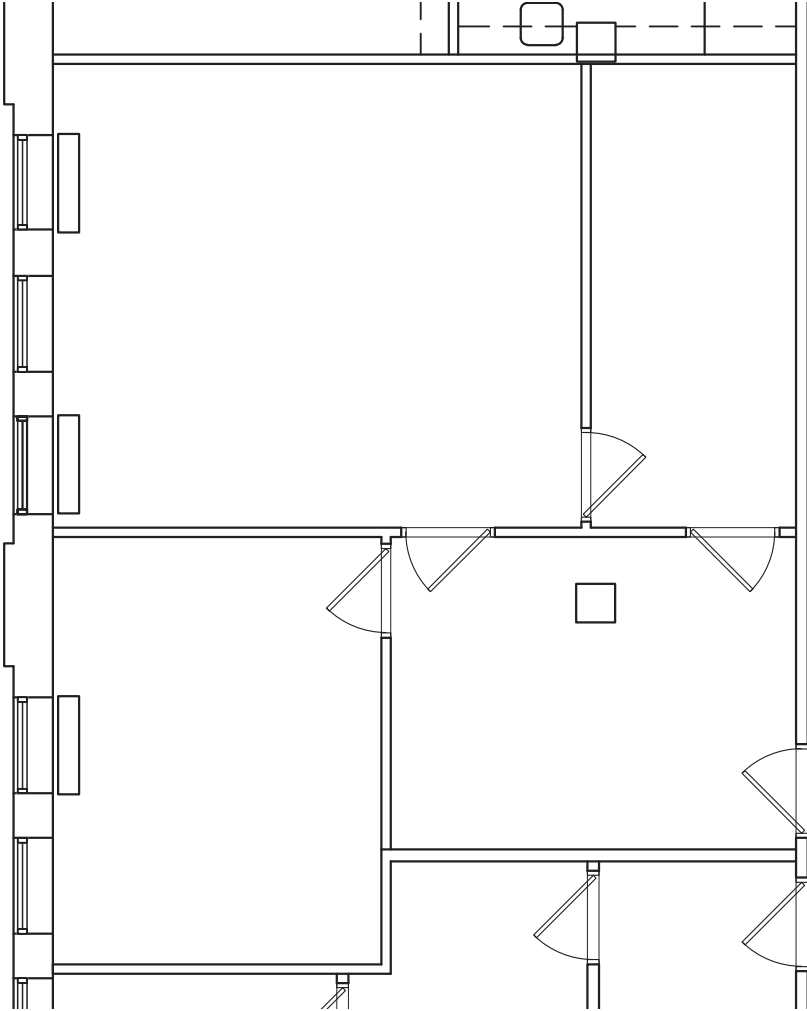
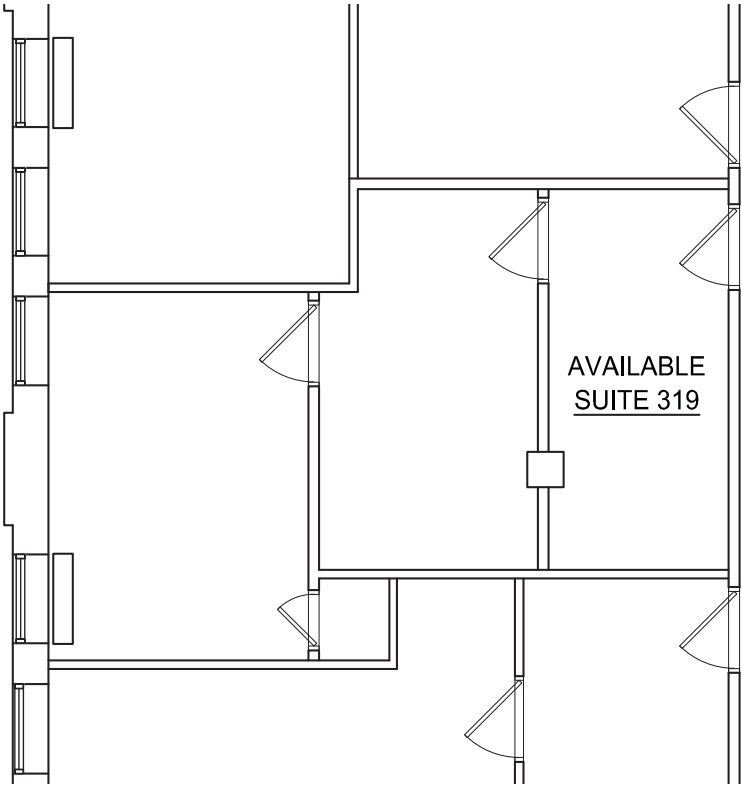

FLOOR PLAN



SUITE 320: 300 SF

SUITE 318A: 310 SF

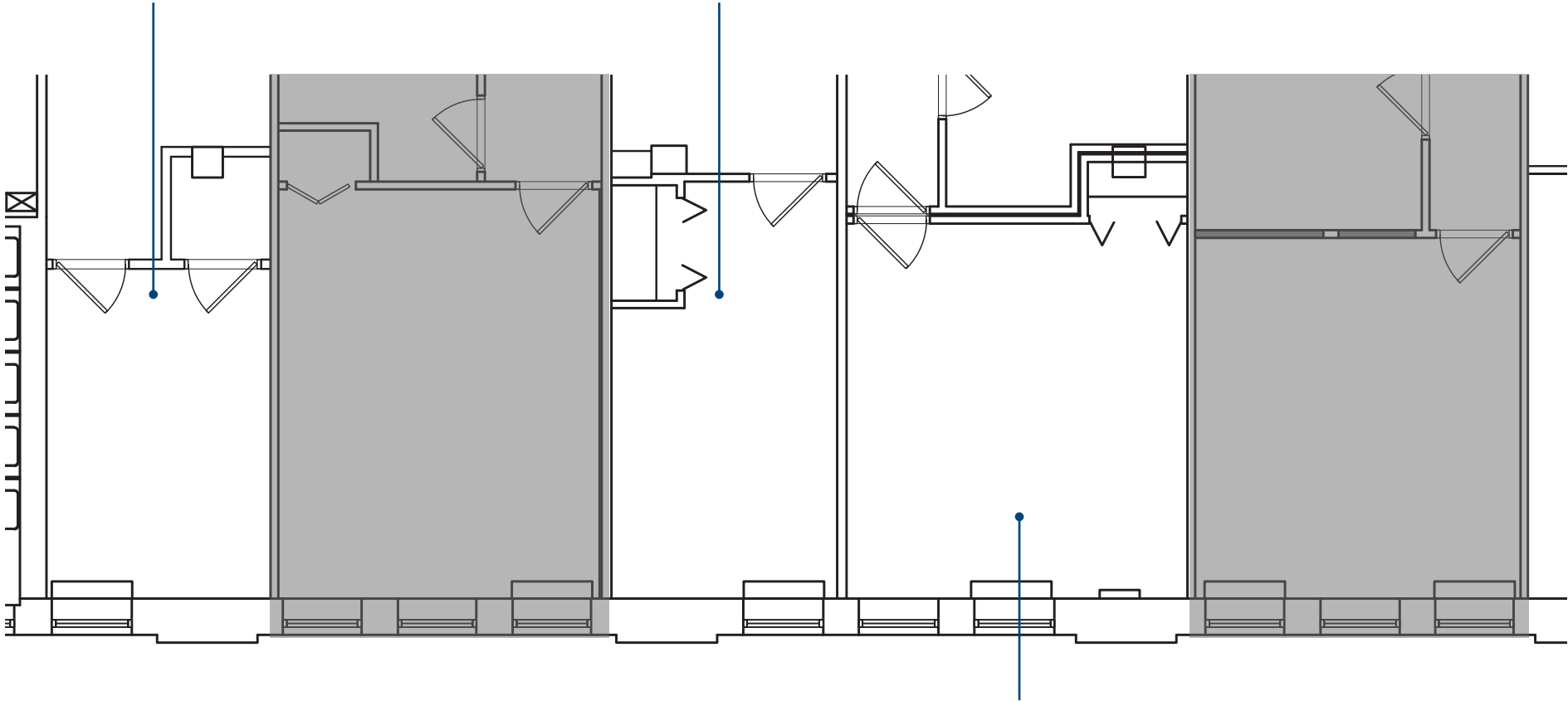

SUITE 322: 462 SF

FLOOR PLAN



SUITE 360: 1,099 SF

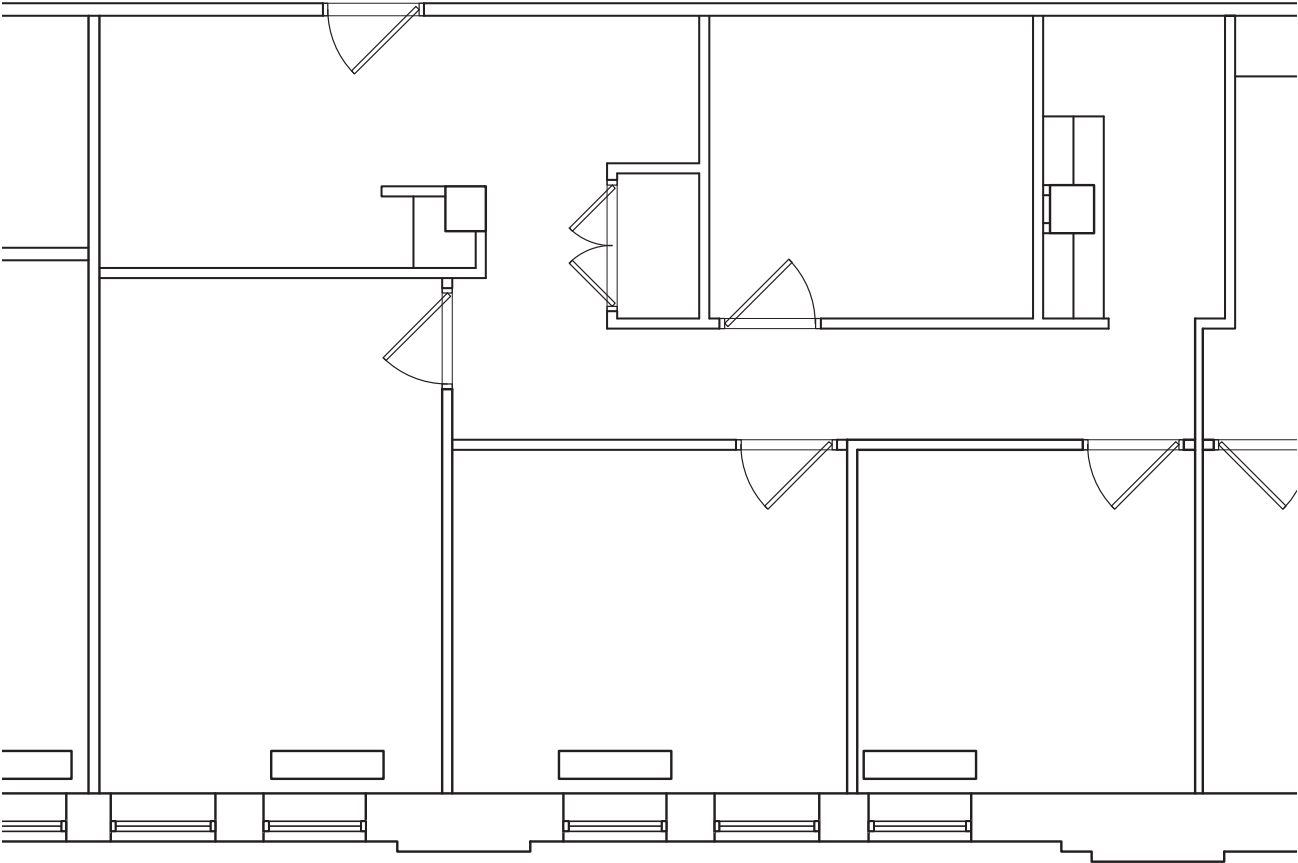

FLOOR PLAN



SUITE 425: 823 SF

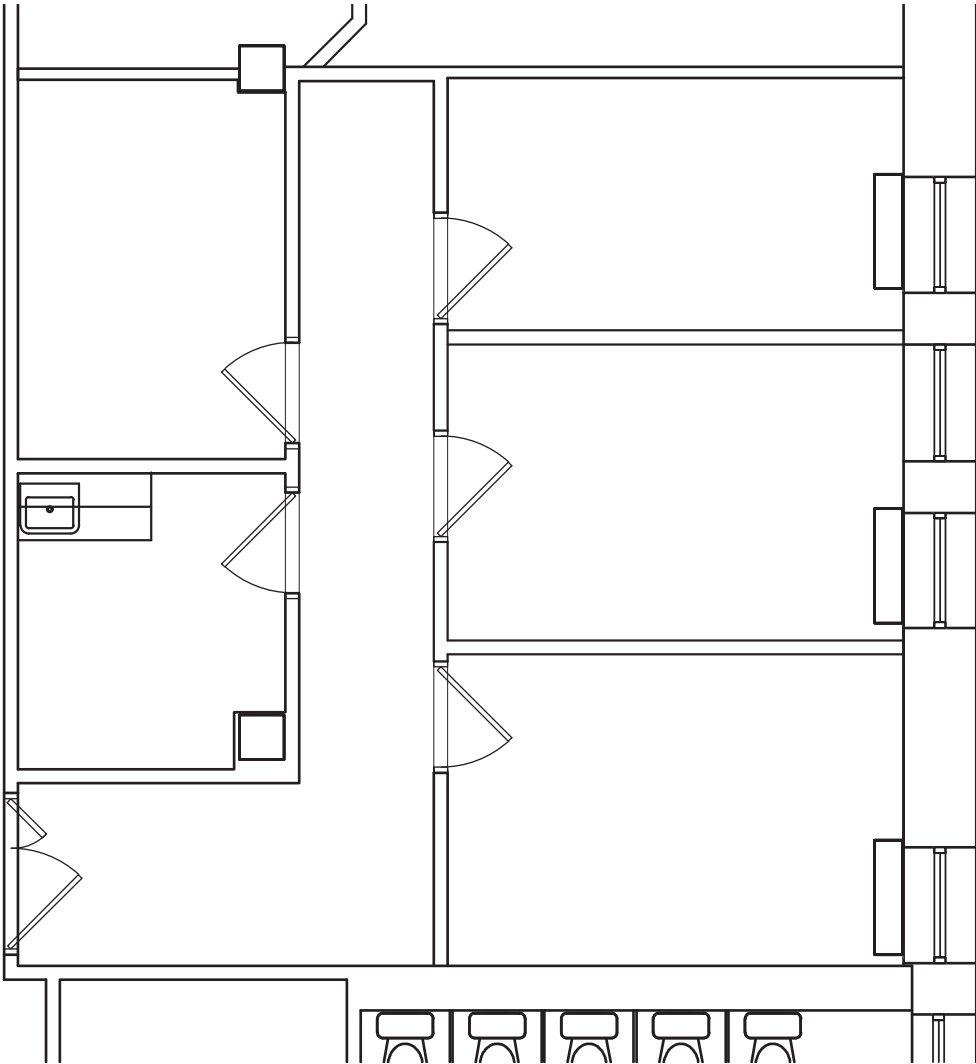

FLOOR PLAN



SUITE 428: 1,117 SF

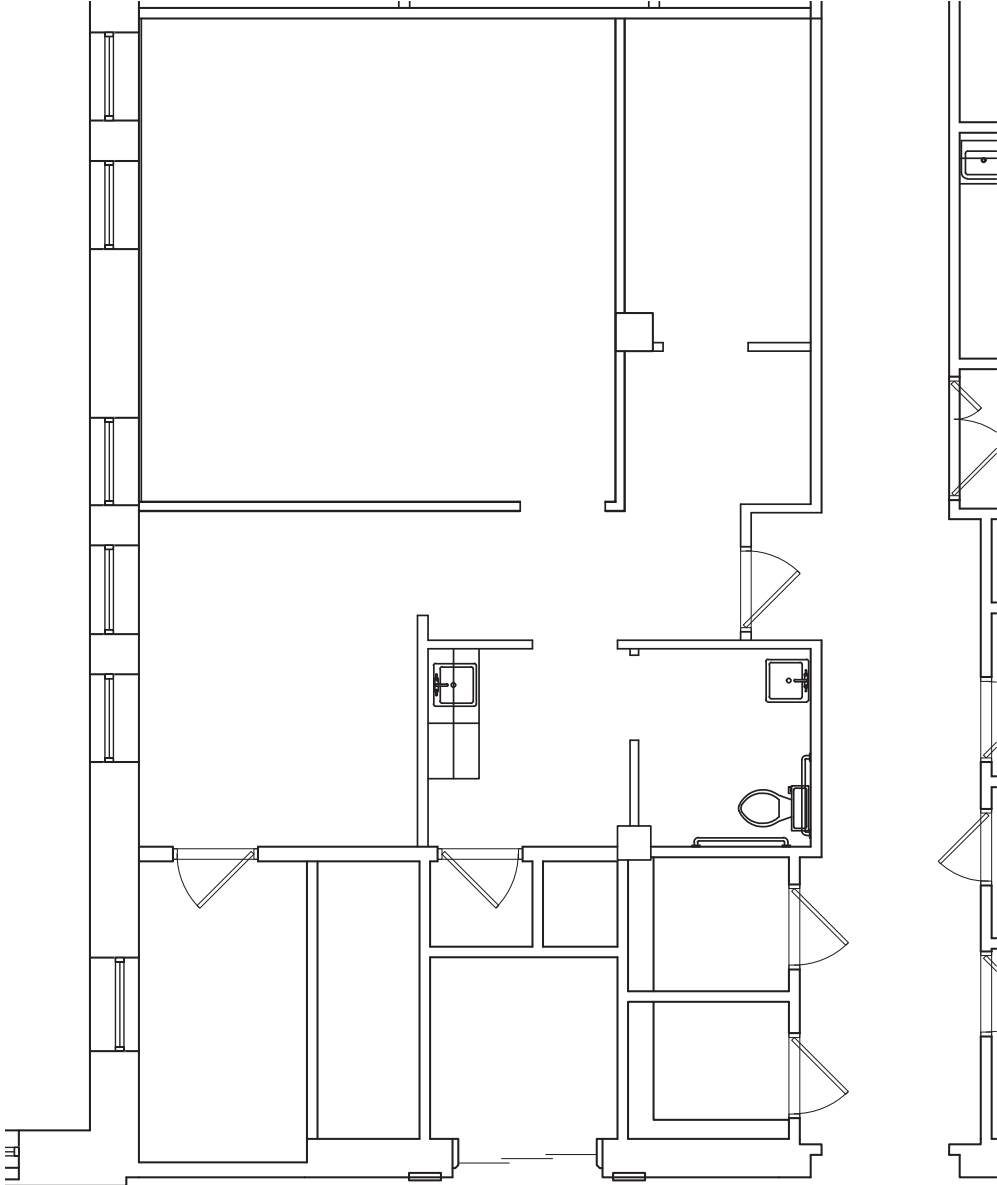

FLOOR PLAN



SUITE 438: 1,883 SF

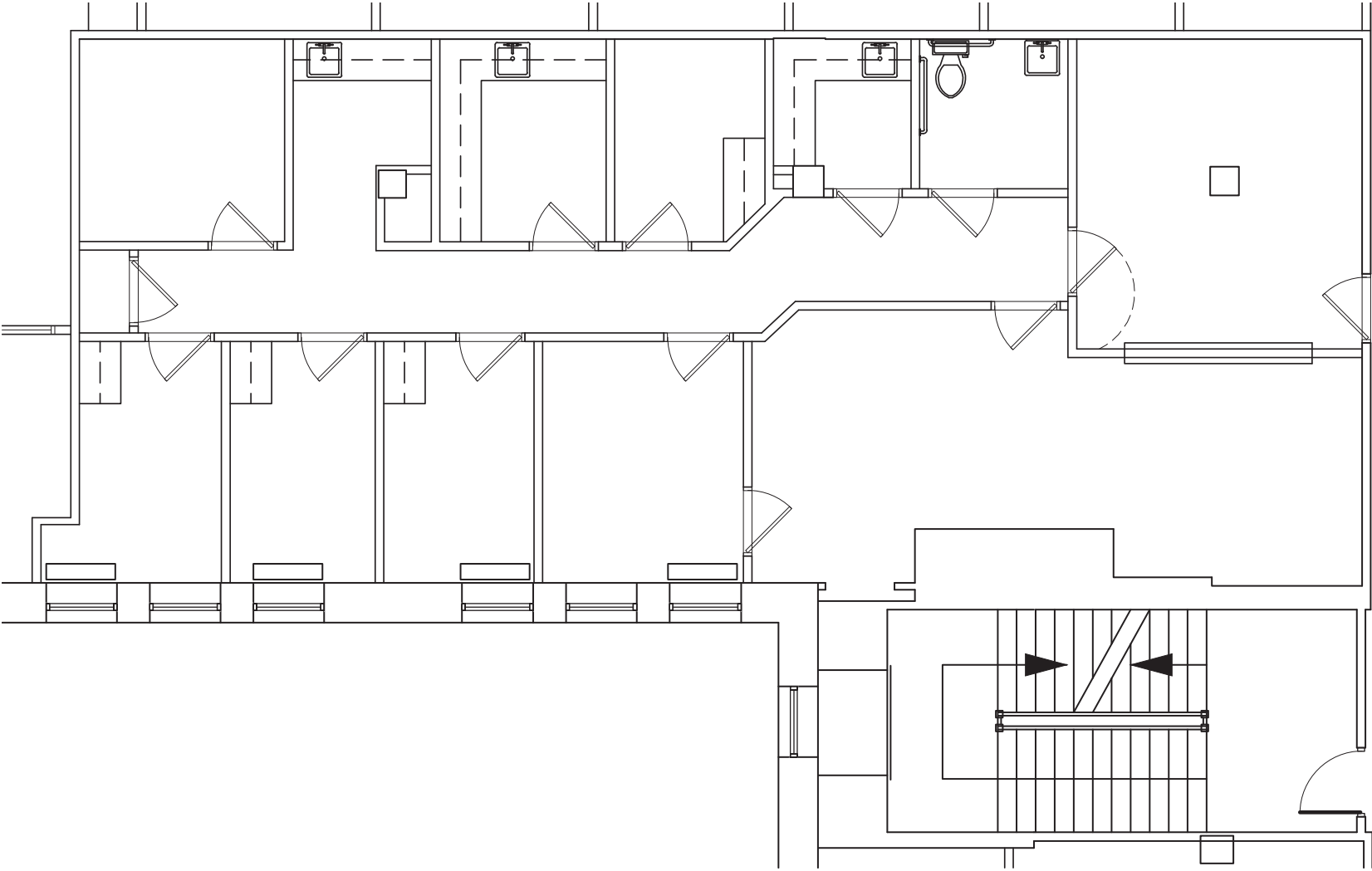

TRADE AREA

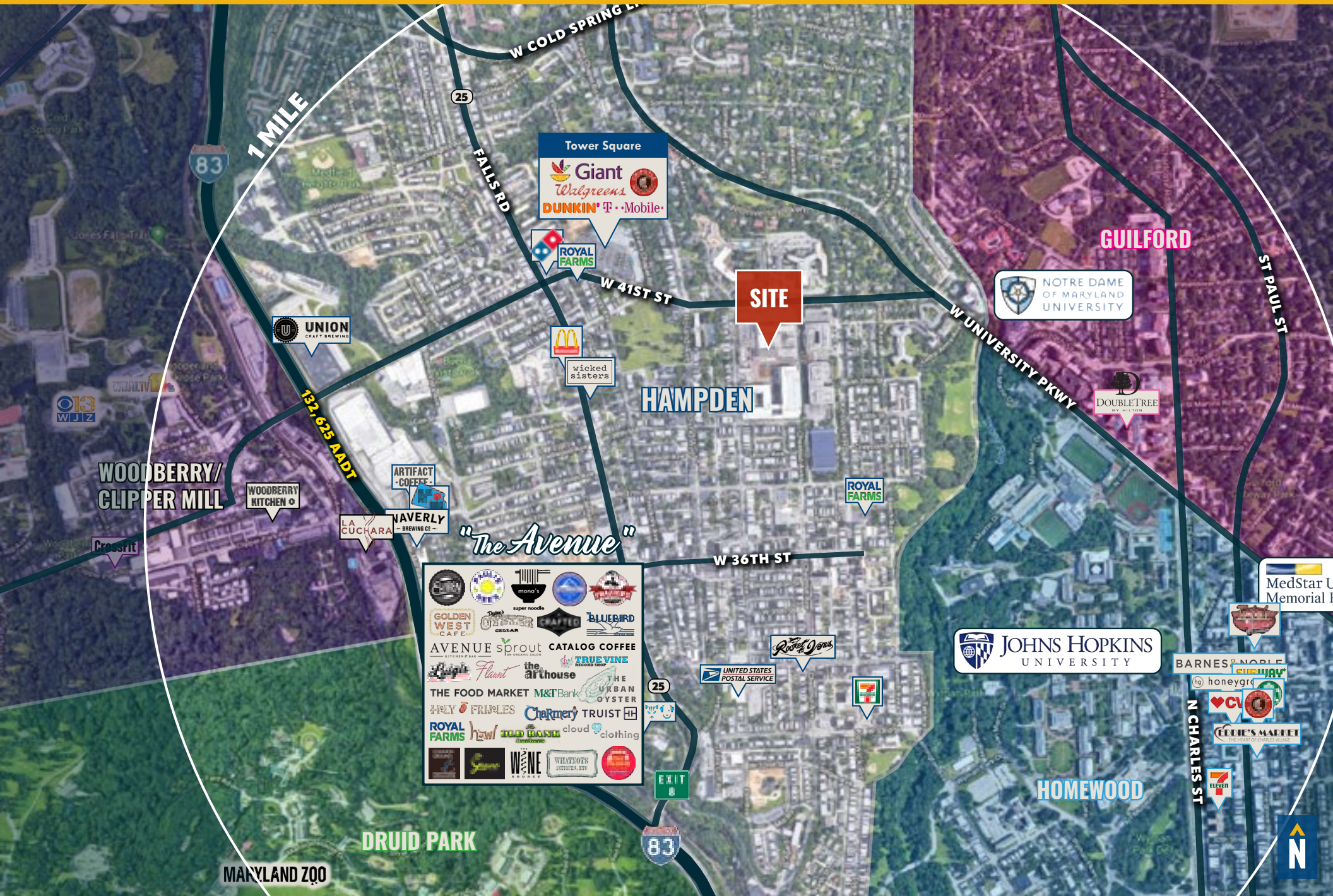

DEMOGRAPHICS

2024

RADIUS:

1 MILE

3 MILES

5 MILES

RESIDENTIAL POPULATION



13,470

118,694

288,249

DAYTIME POPULATION



30,627

228,406

672,389

AVERAGE HOUSEHOLD INCOME



\$130,769

\$92,169

\$99,511

NUMBER OF HOUSEHOLDS



12,928

100,523

249,111

MEDIAN AGE



31.2

37.5

36.5

[FULL DEMOS REPORT](#)

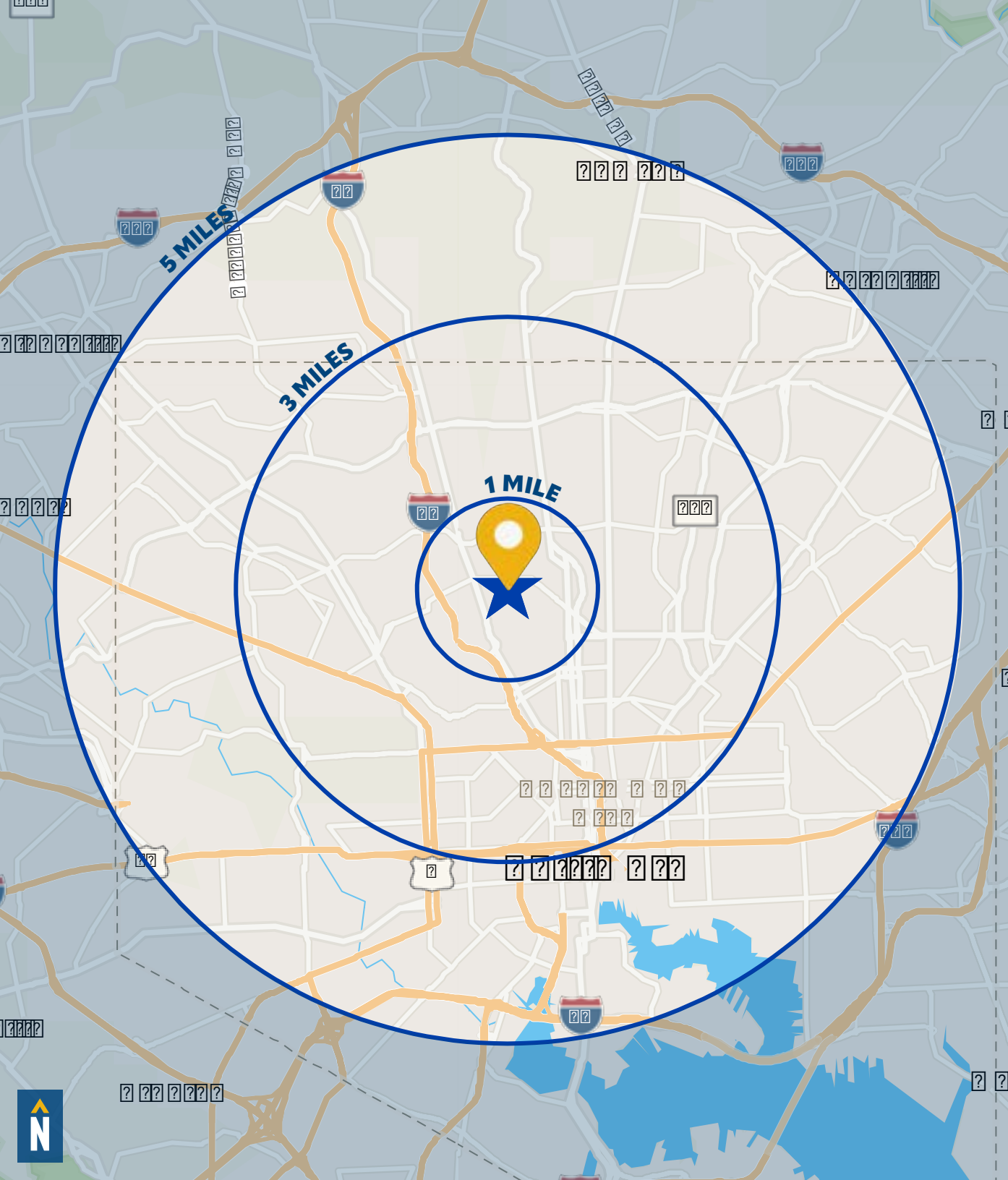

FOR MORE INFO CONTACT:



MATT MUELLER

SENIOR VICE PRESIDENT & PRINCIPAL

410.494.6658

MMUELLER@mackenziecommercial.com



HENSON FORD

VICE PRESIDENT

410.494.6657

HFORD@mackenziecommercial.com



JOE BRADLEY

SENIOR VICE PRESIDENT & PRINCIPAL

410.494.4892

JBRADLEY@mackenziecommercial.com



DYLAN BOZEL

REAL ESTATE ADVISOR

410.494.4896

DBOZEL@mackenziecommercial.com

ROTUNDA

BALTIMORE 1921 MARYLAND



VISIT **PROPERTY PAGE** FOR MORE INFORMATION



MACKENZIE

COMMERCIAL REAL ESTATE SERVICES, LLC

410-821-8585

2328 W. Joppa Road, Suite 200

Lutherville, MD 21093

OFFICES IN: ANNAPOLIS, MD BALTIMORE, MD BEL AIR, MD COLUMBIA, MD LUTHERVILLE, MD CHARLOTTESVILLE, VA

www.MACKENZIECOMMERCIAL.com

No warranty or representation, expressed or implied, is made as to the accuracy of the information contained herein, and same is submitted subject to errors, omissions, change of price, rental or other conditions, withdrawal without notice, and to any specific listing conditions imposed by our principals.